

Mech 313

1.28

Concordia University

Course: Machine Drawing and Design	Number: MECH 313/2	Section: T, X	
Examination: Midterm	Date: Feb. 28, 2001	Time: 2 hours	No. of pages: 4
Instructors: Drs V. N. Latinovic and C. Rajalingham			
Materials Allowed: (1) Textbook: C. Jensen and J. D. Helsel, Engineering Drawing and Design (2) Class notes (3) Calculator			
Special Instructions: (1) Answer all questions. (2) Do not remove the staple pin. (3) Full marks will be given to unambiguous answers.			

Question 1:

(a) Complete the chart given below using the fit tables and indicate the nature and measure of tolerance limits.

Basic size	Fit	Basis	Feature	Limits of size		Limits of fit	
				Max Size	Min Size	Maximum Material	Minimum material
φ1.50	FN2S	Shaft	Hole	1.4986	1.4976	-0.0024	-0.0008
			Shaft	1.5000	1.4994		
φ 35	H7/k6	Hole	Hole	35.025	35.00	-0.018	0.023
			Shaft	35.018	35.002		

(20 Marks)

①

(b) The size of a shaft at maximum material condition is 18.980 mm, and allowable tolerance on the shaft size is  $-0.021$  mm. This shaft is designed to fit into a  $\phi 19$  H9 hole. Determine the fit limits and identify the fit type.

Fit at MMC:  $0.020$  mm ✓

Fit at LMC:  $0.093$  mm

Fit Type: Clearance / Transition / Interference

Hint: The tolerance limit of H9 hole can be read from H9/d9 fit.

(15 Marks)

**Question 2:**

(a) The perpendicularity tolerance of a  $\phi 34.95 - 35.00$  hole is indicated in Figure 2(a). Write down the permissible tolerance and virtual datum size corresponding to each of the feature size indicated in Table 2(a).

Table 2(a):

Size	Tolerance	Virtual datum size
35.00	0.02	34.98
34.99	0.02	34.97
34.98	0.02	34.96
34.97	0.02	34.95
34.96	0.01	34.95
34.95	0.00	34.95

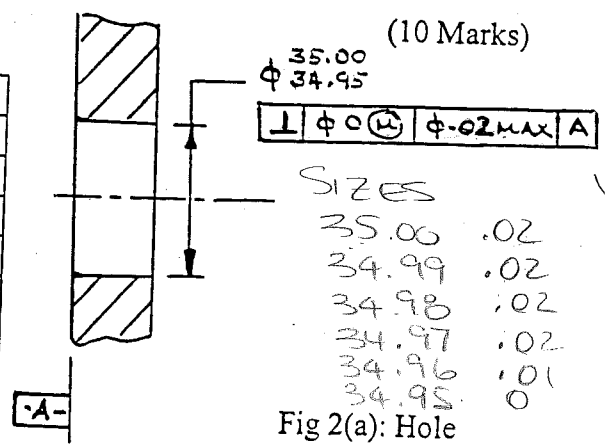

VIRTUAL CONDITION

34.98
34.97
34.96
34.95
34.95
34.95

(b) Draw the front and top views of the stand shown in Figure 2(b) and indicate all necessary the dimensions. Include the following tolerance requirements also in these sketches.

- The bottom surface is primary datum A. The permissible flatness tolerance of this surface is .004.
- The top surface has to be parallel to datum A within .003.
- The left side surface is the secondary datum B. This surface has to be perpendicular to datum A within .003
- The front surface is the tertiary datum C. This surface has to be perpendicular to A and B within .003
- The variation of  $\phi 1.00$  hole from its true position with respect to datums A, B and C is not allowed to exceed .002 at MMC.
- The limits of size of the 7.00 width are equivalent to those of a  $\phi 7.00$  shaft in RC7 (basic hole) fit.
- The top surface is to be machined to N6 roughness.

(30 Marks)

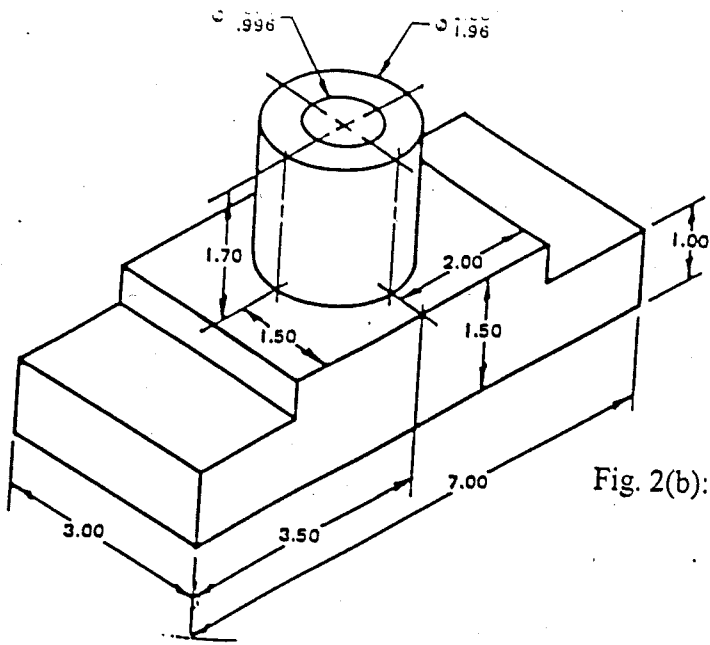
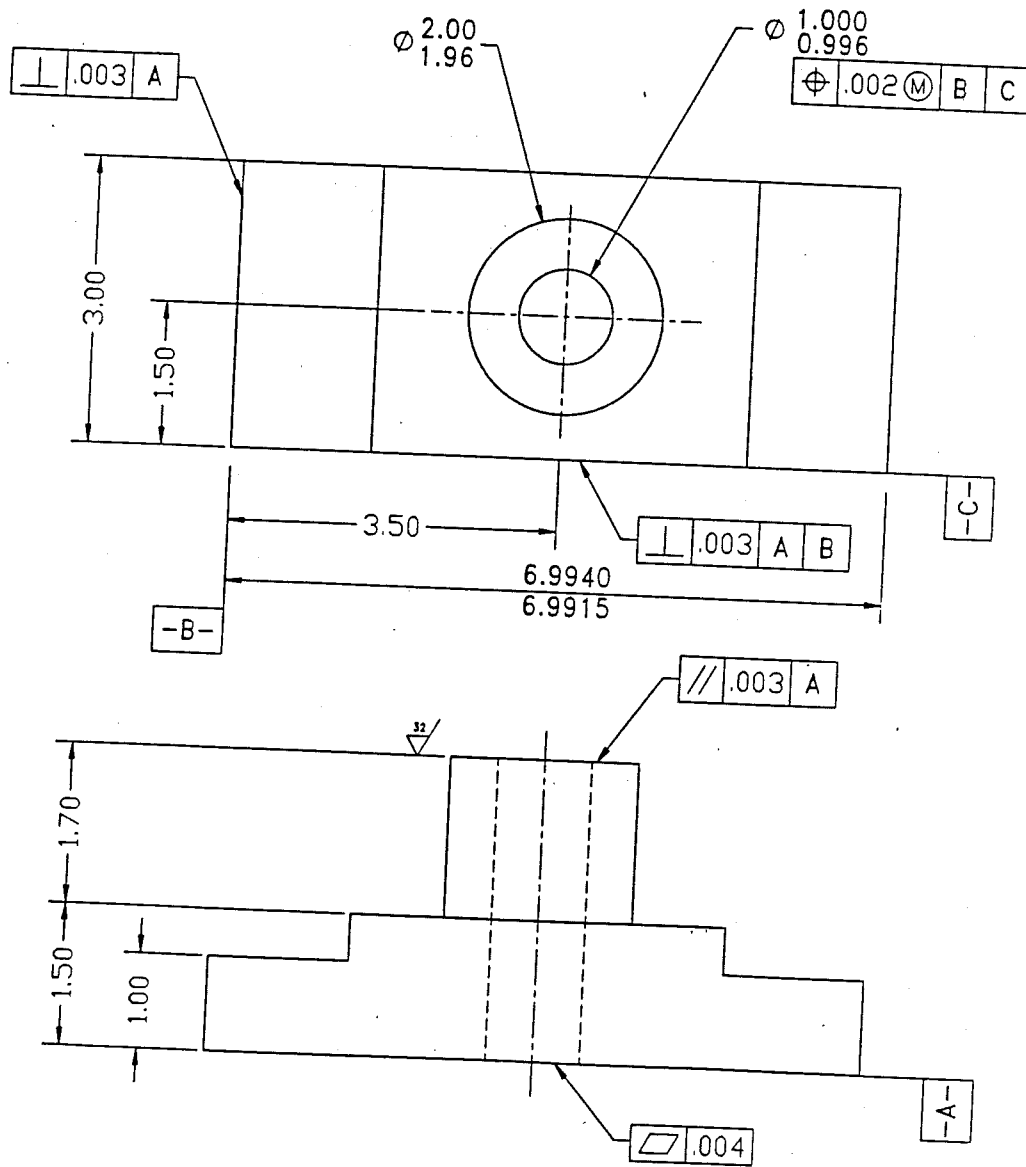

Fig. 2(b): Stand



**Question 3:**

A 10 mm thick cover plate is fastened to a 40 mm base plate using a 40 mm long M16 fine thread hexagonal-head cap screw and a spring lock washer. The cover plate is spotfaced to seat the washer. Draw the full size sectional view of the fastener assembly and provide the dimensions of the holes and threads.

(25 Marks)

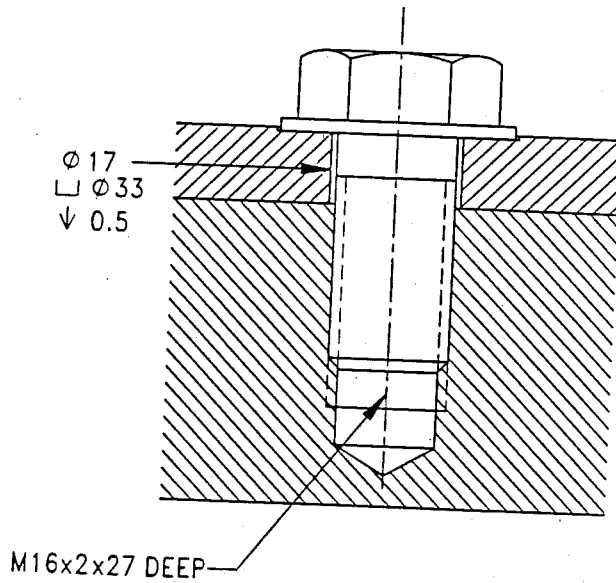

Test

Name

ID

Date: 03/03/03

Hint: datum is to be defined using a surface that is further machined and important to position the holes.

The component *shaft pivot support* is fabricated from a casting that has a machining allowance of 2mm on the faces that are machined further to a surface roughness of  $1.6\mu\text{m}$ . Select three datum A, B and C that are essential to define the position of the holes H1, H2 and H3. The dimensions indicated in the drawing correspond to the dimensions after machining, whenever possible.

Make a working drawing with a front view and two side views after incorporating the following details. Use a proper scale.

1. Define the horizontal surface that sits on the Central Pivot CP, as Datum A with a flatness of  $0.02\mu\text{m}$
2. Define the vertical face on the hole H1 that butts with the shoulder of the horizontal shaft S1 as Datum B with a flatness of  $0.02\mu\text{m}$ .
3. Define the third datum C that is perpendicular to both A and B with a flatness of  $0.02\mu\text{m}$ . Choose an edge of the 10mm thick base of the shaft pivot support.
4. Dimension the position of the holes using the datum for defining geometrical tolerance. All the holes have a positional tolerance of  $50\mu\text{m}$  with reference to all datum A, B and C. In addition, the hole H3 has to be concentric with reference to hole H2 with in  $0.02\text{mm}$ .
5. The distance between the faces of the holes H2 and H3 has the dimension of  $134.00\text{H7/k6}$
6. Indicate the obligatory machining surfaces with an allowance of 2mm.
7. Indicate all the machined/drilled surfaces with a roughness of  $1.6\mu\text{m}$ .
8. The fit with the central pivot is H7/g6 while the fit between the horizontal shaft and holes H2 and H3 is H9/d9. Dimension the part to satisfy these fits.

**BONUS QUESTION**

9. What is the diameter of the shaft if you use the virtual diameter of the hole as the design diameter?

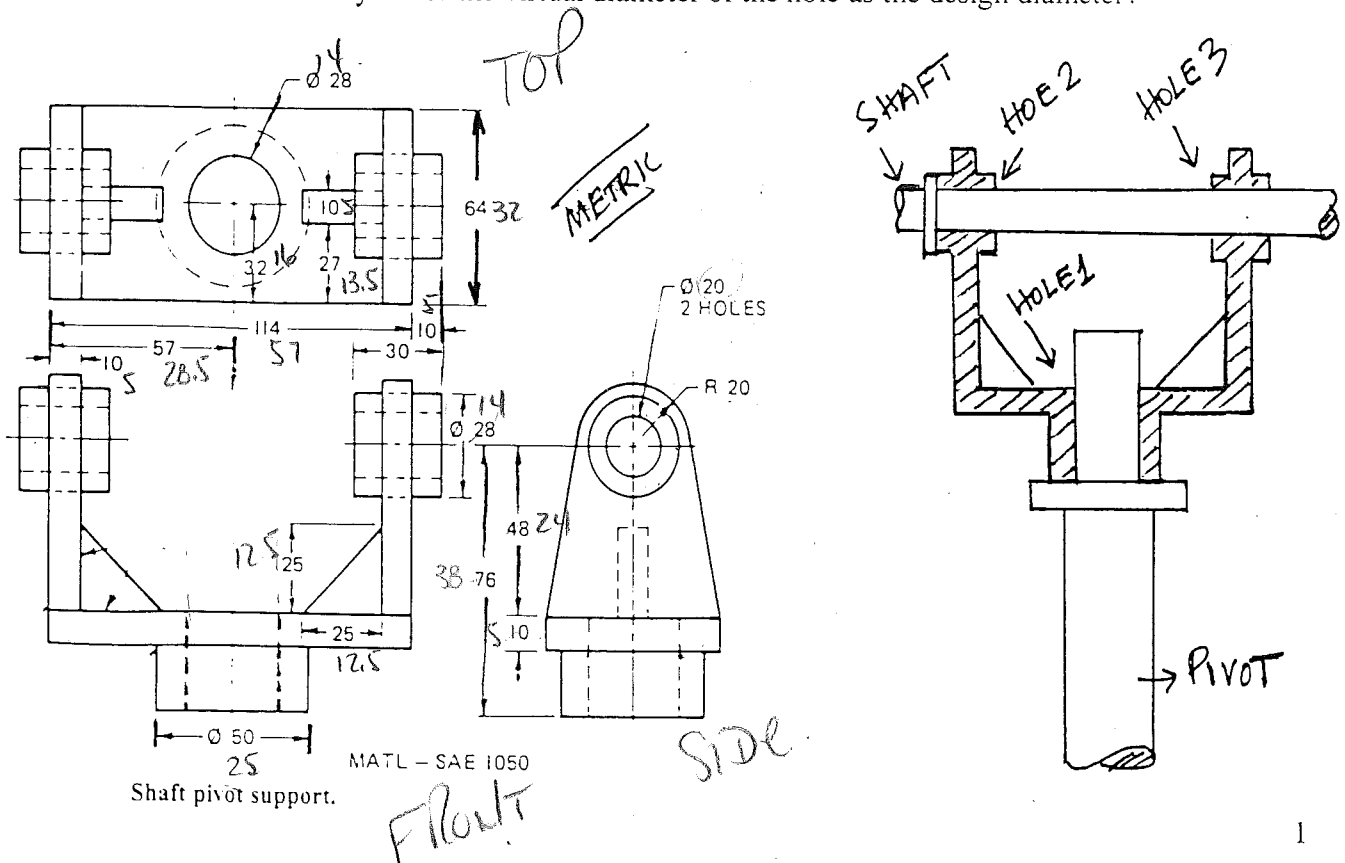

Quiz 2

CLOSED BOOK MIDTERM EXAMINATION

Name \_\_\_\_\_

ID \_\_\_\_\_

Date: 03/03/03

**Multiple choice** Circle the answer that best fits the question.

1. Select a shaft-basis medium drive fit.  
 a) H7/H8    b) H7/k6    c) S7/h6    d) k6/H7
2. What would be the MMC dimension of the hole if a maximum interference of 30µm is needed for shaft of 45.000/44.975?

- a) 45.000    b) 44.975    c) 45.030    d) 44.970

0.03 Max Int: Min hole - Max shaft

3. The connecting rod shown in the figure is designed for locating the two halves accurately and also for frequent

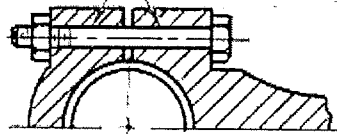

0.03 = Min hole - 45.000  
 45.000 + 0.03 = 45.03

assembly and disassembly. Suggest a suitable fit.

- a) LC6    b) FN4    c) RC9    d) FN1

(C) CONNECTING-ROD BOLT

4. For the fit 100H7/s6, hole dimension is 100.035/100.000 and shaft dimension is 100.093/100.071. What is the maximum interference possible?

- a) 71µm    b) 93µm    c) 36µm    d) 58µm

MAX int = Min hole - Max shaft  
 100.000 - 100.093

5. The virtual dimension is constant for

- a) RFS    b) LMC    c) MMC

6. What is the dimension to be considered for the worst fit situation when feature size has both linear and geometrical tolerance

- a) MMC    b) LMC    c) RFS    d) Virtual

8.2

7. The drawing reads

What is the allowed positional tolerance if the actual size is φ8.2?

- a) 0.25    b) 0.45    c) 0.5    d) 0.05

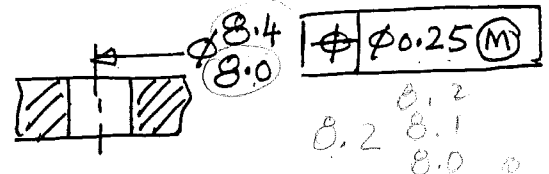

8.2  
 8.2 8.1  
 8.0

8. Suggest a minimum full-thread length for the internal thread in order to fasten plate A with Plate B.

- a) 16    b) 20    c) 10    d) 25

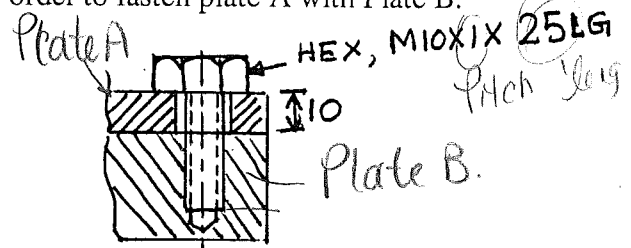

9. What is the minimum size of the hole for the above case of fixed fastener assembly, if both the internal thread and the hole have a positional tolerance of 0.05mm

- a) 10.2    b) 10.1    c) 9.9    d) 10.05

10. Suggest the minimum size of the hole for the floating fastener assembly.

- a) 10.2    b) 10.1    c) 9.9    d) 10.05

THE HOLES HAVE

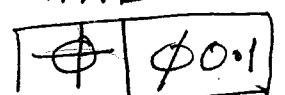

M10 X 1.25 X 50 LG

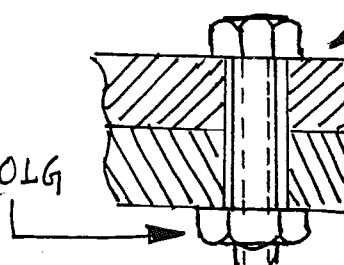

# Quiz I

MACHINE DRAWING AND DESIGN, MECH 313/4, WINTER 2003

Section T, Instructor: Dr. M.Packirisamy

## CLOSED BOOK EXAMINATION

Name \_\_\_\_\_

ID \_\_\_\_\_

Date: 27/01/03

**Multiple choice** Circle the answer that best fits the question.

1. Which is the hole-basis system?

- a) H7/H8    b) H7/k6     c) K6/h7    d) k6/H7

2. What would be the probable 50H7 tolerance limits?

- a) 50.500/50.000    b) 50.000/49.500    c)  50.025/50.000    d) 50.000/49.975

3. Select the largest clearance class of running/sliding fit.

- a) RC1    b) LT4    c)  RC9    d) LC9

4. What type of projection is

- a) 3<sup>rd</sup> angle    b)  1<sup>st</sup> angle    c) mirrored    d) ANSI

5. Select a fit for permanent assembly of a steel pin into a casting.

- LN4    b) LC1    c) H7/h6    d) H11/c11

6. If shaft size is  $\phi 10.019/10.010$  and hole size is  $10.015/10.000$ , the maximum interference is

- 0.019    b) 0.015    c) 0.004    d) 0.005

*Max inter = largest shaft - smallest hole.*

7. For the above problem, what is the maximum clearance?

- a) 0.019    b) 0.015    c) 0.004    d)  0.005

*Smallest shaft - biggest hole.*

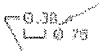

8. Identify this  with the right symbol.

- a)     b)     c)     d) 

9. Which condition results in maximum clearance?

- a) MMC    b)  LMC    c) RFS    d) none of the above

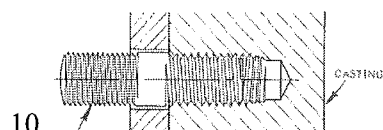

10. Identify the threaded part.

- a) Bolt    b) screw    c)  stud    d) locating pin